

# oikos x

6-axis machining centre for structural beams and wall panels

CNC machining centres for Timber construction



REV. N. 02 - 03.2019



SCM GROUP SPA  
via Casale 450 - 47826 Villa Verucchio, Rimini - Italy  
tel. +39 0541 674111 - fax +39 0541 674274  
scm@scmgroup.com  
www.scmwood.com



00L0501961E



**NEVER STOP IMPROVING**



THE NEW MACHINING CENTRE  
FOR TIMBER CONSTRUCTION:  
**EVER MORE TECHNOLOGICAL,  
EVER MORE PERFORMING.**

6

OIKOS X

## TECHNOLOGY

10



Any kind of machining operation on all sides of the component with no rotation or repositioning required, thanks to the innovative 6-axis architecture.

The new generation machining head unit, with its interpolated movements, allows performing any geometry reducing downtime and increasing the machine flexibility.

The strategic position of the tool stores allows to optimize tool change time.

Possibility to use special aggregates for the execution of the whole range of operations necessary in the sector of wood construction.

## PRECISION

16



Laser probe option to achieve unrivalled accuracy.

State-of-the-art technical solutions: The pressure rollers on the carriages ensure the stability of the work piece, so that no play occurs during processing.

Powerful and sturdy structure allowing to absorb mechanical stresses and to execute precise complex operations.

The machine bed fixed directly to the workshop floor, without the need of masonry construction, guarantees greater stability for high performances.

## PRODUCTIVITY

18



Significant reduction in tool change phases, thanks to the innovative integrated tools, designed by SCM, for the rapid and precise implementation of timber frame projects.

## CUSTOMIZATION

20



Automatic loading and unloading systems with customized solutions for different applications.

Expandable infeed and outfeed buffers for a high degree of configurability.

Technical solutions aimed at eliminating the risk of damaging the component surface.

Possibility to manage glulam beams and elements for ceilings and walls as well as round beams, "uso fiume" beams, etc. by means of specific devices.

## CLEANLINESS

24



Excellent containment of the wood dust and shavings inside the cabin and subsequent automatic elimination, to guarantee a constant and efficient cleaning of the work area.

No more dust outside the cabin, thanks to the new self-closing casings that separate the work area from the external environment.

Intelligent management of waste and short pieces: the key role of the motorized conveyor belt inside the cabin.

## EASE OF USE

26



eye-M console available to the operator to control the machine in the most rapid and effective way.

Maestro beam&wall is the software designed and developed by SCM that makes programming and use of the machine simple and intuitive.

Possibility to manage complex projects elaborated as nesting processing, for the production of modular structures.

32

Applications

36

Technical data

# OVERVIEW OF TECHNICAL FEATURES

TECHNOLOGICAL ADVANTAGES



**High degree of automation,** thanks to the motorized chains loading system with clamps for optimal grip of work piece and automatic positioning on the roller conveyor.



**No friction or damages of the element** thanks to roller lifters.

**Strong and precise handling** of the element by means of large-sized self-centering clamps.



**High accuracy** ensured by horizontal and vertical pressers with electronic positioning.

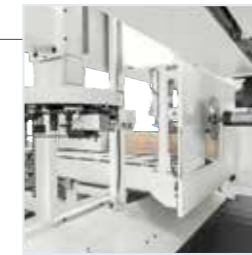

**Machining head unit with optimized tool change phase,** thanks to the tool stores positioned strategically in relation to the work area.

**Simple unloading of the processed element,** by means of a rear mechanical pusher.

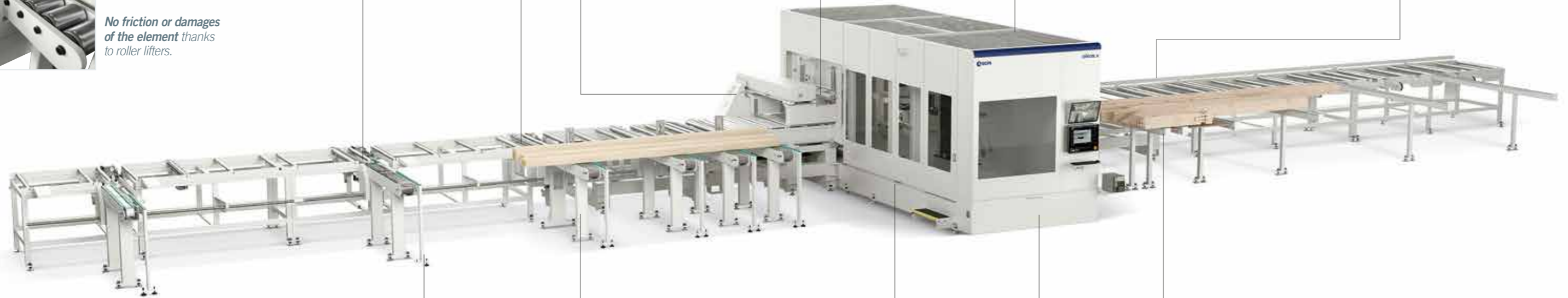

**Easily extractable supports** to place packages of beams in front of the loading chains.

**Possibility of positioning a set of beams** using the motorized chains loading system with buffer.

**Maximum safety for the operator,** cleaning of the work area and containment of dust thanks to the integral and pressurized protection cabin.

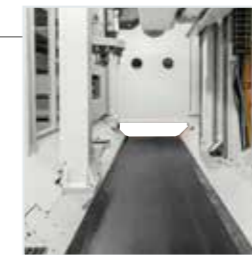

**Efficient shavings removal** by means of the bidirectional motorized conveyor belt, ensuring a constant cleaning of the work area.

**Storage and easy pick up of elements** from the outfeed buffer equipped with parallel supports.

# OVERVIEW OF TECHNICAL FEATURES

TECHNOLOGICAL ADVANTAGES



Rapid 15 tool store positioned near the work area to reduce tool change time.



6-axis machining head unit for maximum production flexibility.

New motor-driven casings for accurate isolation of the work area from the external environment.

Video surveillance system for real-time monitoring of the entire machining process.

Maximum ergonomics thanks to the new eye-M console with a 21.5" touch screen.

Large windows in Lexan allow the operator to have wide visibility during the work phases in conditions of high safety.

Simple identification of each element thanks to "label printing" at the end of processing.

Additional aggregates for the manufacturing of the whole range of geometries used in the sector of wood construction.

Machine bed firmly on the workshop floor. No need of masonry construction.

Intelligent management of short work pieces: front door for their simple and quick recovery.

# MACHINING HEAD UNIT

**oikos x**

6-axis machining centre for structural beams and wall panels

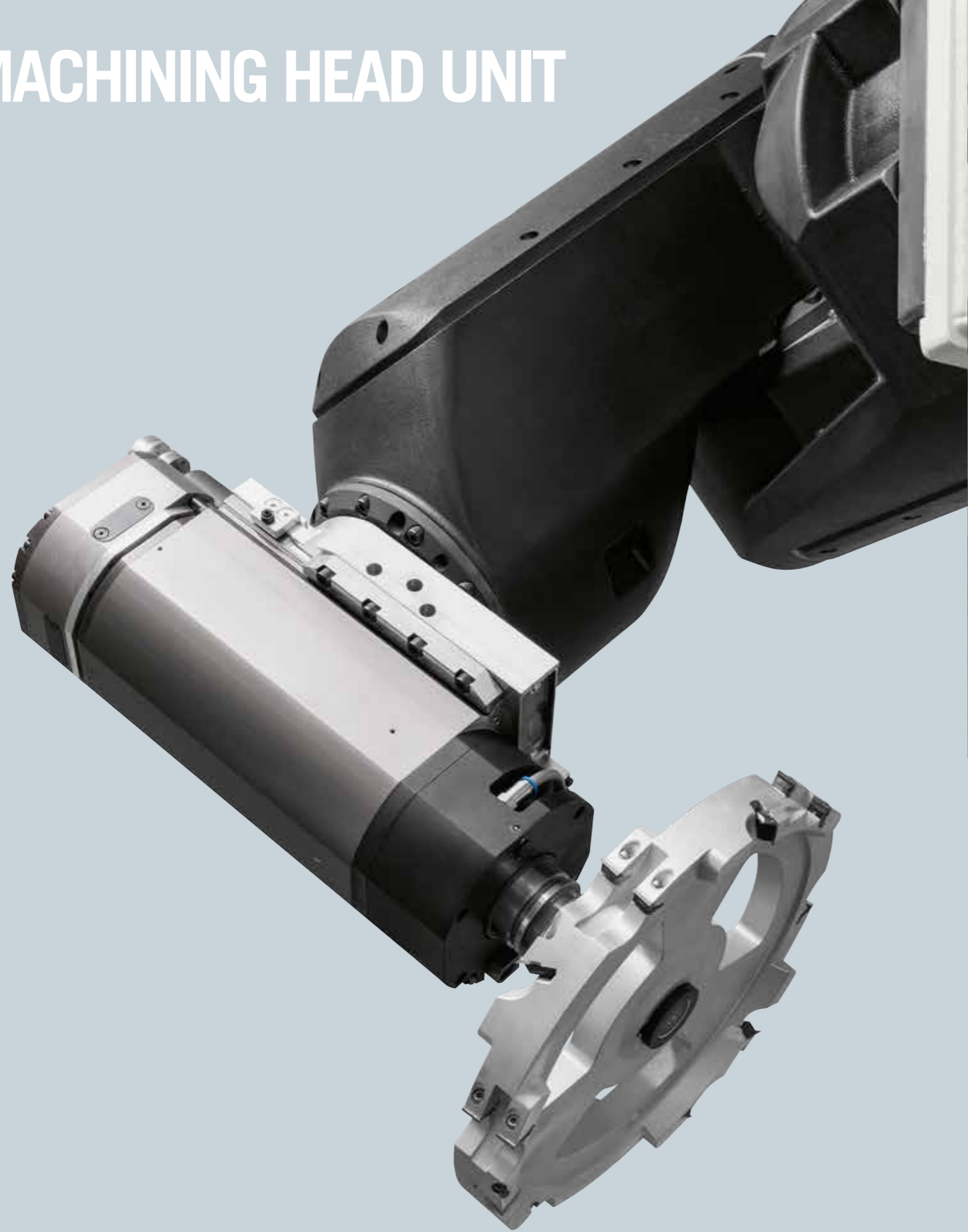

Its **perfect symmetry** allows processing both ends of each element in minimum overhang conditions for a greater accuracy. Elements with required operations on all sides are **processed in a single set up**, thus with no rotation or repositioning need.

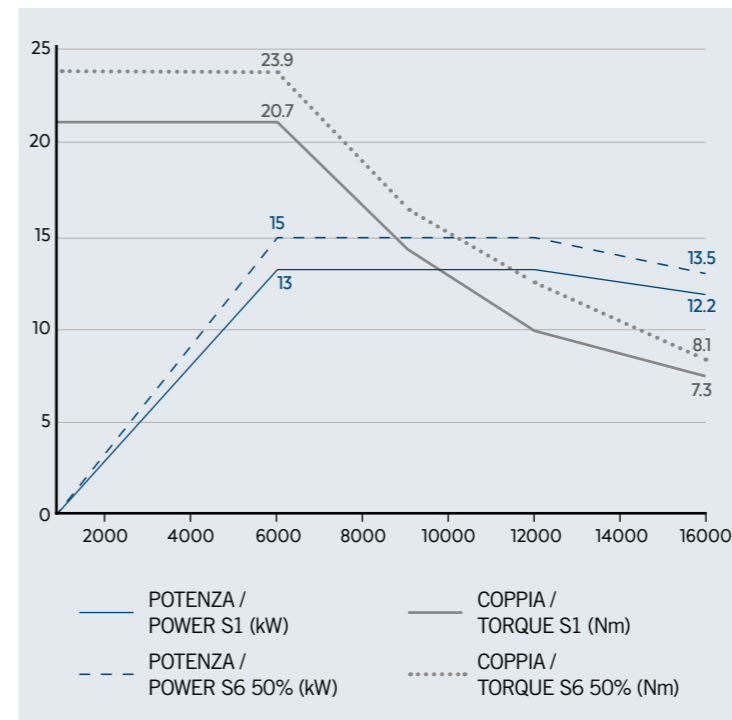

Machining head unit with specific electrospindle to perform at **maximum speed and with maximum finishing quality**, all necessary operations for the production of beams and elements for wooden houses.

The electrospindle, designed and built by SCM, develops a power of **13 kW at 6000 rpm**, to use tools of large dimensions and achieve a maximum rotation speed of **16000 rpm**.

The application of an inverter allows to adjust the rotation speed of each tool, in order to **maximize the finishing quality of all operations**.

# TOOL STORES



Up to 18 positions, to always have on board all the tools necessary for the manufacturing of the whole range of geometries used in the sector of wood construction. Tools always ready to use. The Rapid 15 tool store is positioned at a minimum distance from the work area allowing to execute tool change very quickly. An additional position is provided for the chainsaw aggregate or tools of up to 15 kg weight.



Upper position dedicated to a sawblade of 600 mm maximum diameter.



Lower position dedicated to the mortise chain aggregate or tools of up to 15 kg weight

# AGGREGATES

**oikos x**

6-axis machining centre for structural beams and wall panels



Chainsaw aggregate for the execution of precise, slant and 90 ° cuts, in particular on wall panels with nesting technology.



Rapid movements within the material. Chain thickness 7 mm.



Mortise chain aggregate dedicated to hardware slots, blind or pass through, of up to 310 mm depth.



Execution of slots of 8,10,12 mm thickness.

# MARKER



Extremely fast marking operations on all sides of the element and at any angle.



The pressurized ink pen is placed in a pneumatic device able to take it outside machining area if not in use.

**No tool change required.** The positioning of the device on board of the machining head unit allows to optimize the marking operation with a simple 90° rotation.

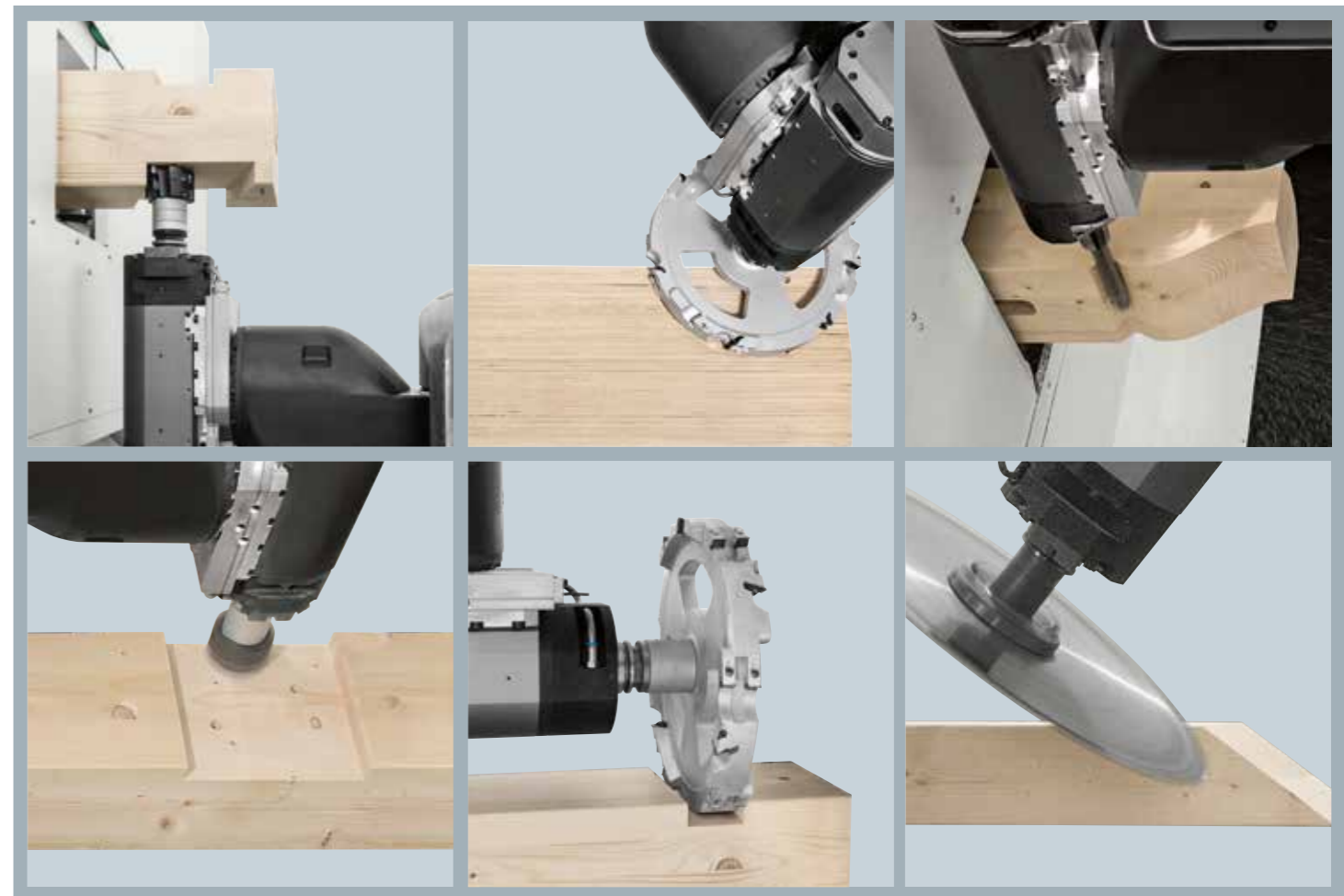



# LASER PROBE AND PRESSURE ROLLERS



Laser probe detects the exact position on the element side where operation must be performed, to guarantee high accuracy.

The touch probe cycle is very fast: **laser reading speed is so high that it can be executed in 3 seconds.**

It is placed on the machining head unit in a special pressurized housing, in order to be protected from dust during processing.

Ideal for the execution of dovetail joints and pockets.

**The horizontal and vertical pressers**, managed by the numerical control, with a **“self-centering” closing movement**, automatically adapt to the element section and **“guide”** it in the work area.



The position of the pressure rollers near the machining area, allows to minimize the stress generated by the tool on the work piece, ensuring a **high degree of accuracy.**

# STRUCTURE

**oikos x**

6-axis machining centre for structural beams and wall panels

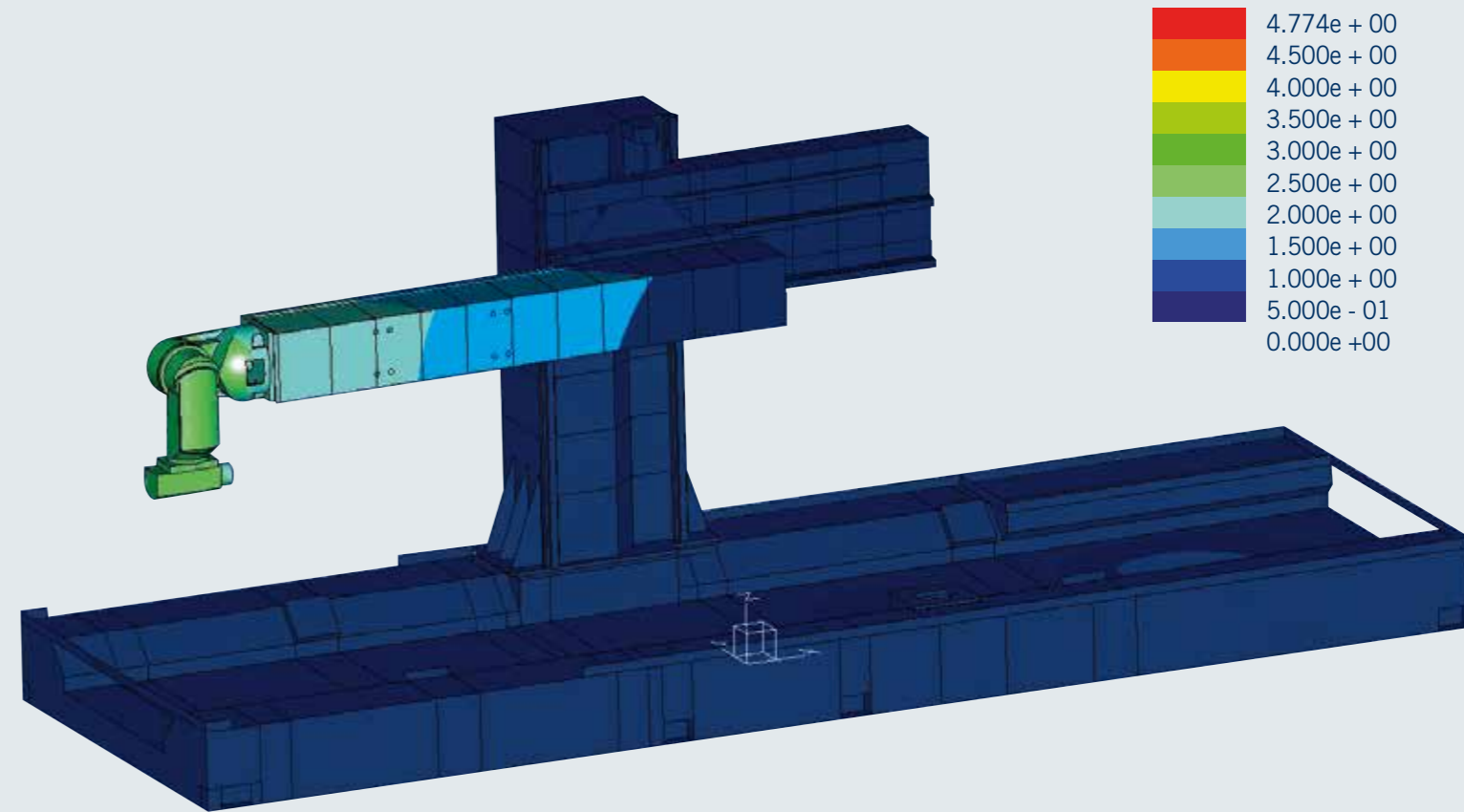

**100% MADE IN ITALY**

First quality materials, unrivalled mechanics.

**Zero vibrations.** The whole structure, validated during the design phase through the FEM-analysis, is extremely strong and solid, therefore ensuring optimal absorption of the stresses generated during element processing. The machining centre can thus perform complex and heavy operations with different tools.

Machine bed, drive carriages and carriages with clamps are firmly anchored to the workshop floor and allow a perfect parallelism between the sliding surface of the element and the floor, allowing to obtain **top quality end products.**

The **high accuracy maintained over time** makes Oikos X a machining centre destined to be a first choice investment.

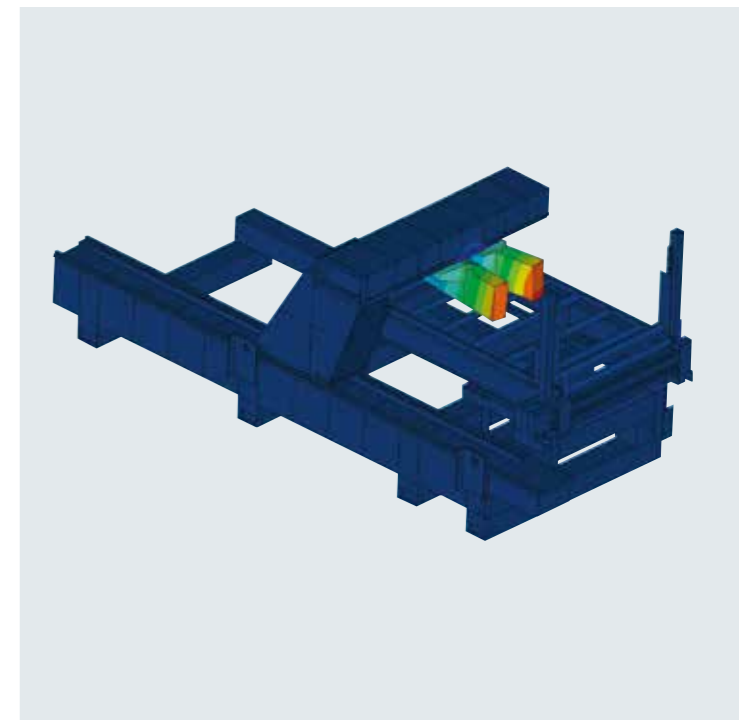

# INTEGRATED TOOLS



**SCM innovation.** Two special tools make it possible to significantly increase the productivity of Oikos X by eliminating the tool change phases and reducing machine downtime.

The “**integrated tool**” represents the ideal solution for processing simple elements, such as rafters of a roof truss.



Made up of a support fully compatible with the electrospindle and with the tool stations inside the cabin, the “integrated tool” can host a 440 mm diameter sawblade and a cutter at the same time for making slots and pockets.

**Integrated sawblade and dovetail cutter**, for the execution of “male” dovetails in a single pass. Maximum cross section compatible with integrated tool 200 (H) x 300 (L) mm.



**Integrated sawblade and rough cutter**, for the execution of blind or pass through pockets. Maximum cross section compatible with integrated tool 200 (H) x300 (L) mm.

# LOADING SYSTEM



The loading system allows to place a set of beams on the infeed buffer and to automatically manage the single beam quickly and accurately.



Composed by a series of supports with variable centre distance, it allows the loading of elements with minimum length 1,200 mm and maximum length up to 19,000 mm.

Special clamps, positioned immediately after the loading buffer, lock the first element and transport it to the centre of the loading roller conveyor. At the end of the loading cycle, these devices return to the initial position ready to lock the next element.



The element is locked and moved along the longitudinal axis by a carriage equipped with a clamp that ensures optimal grip in all conditions. The jaws of the clamp are self-centering hence the beam is always aligned to the centre of the loading roller conveyor.

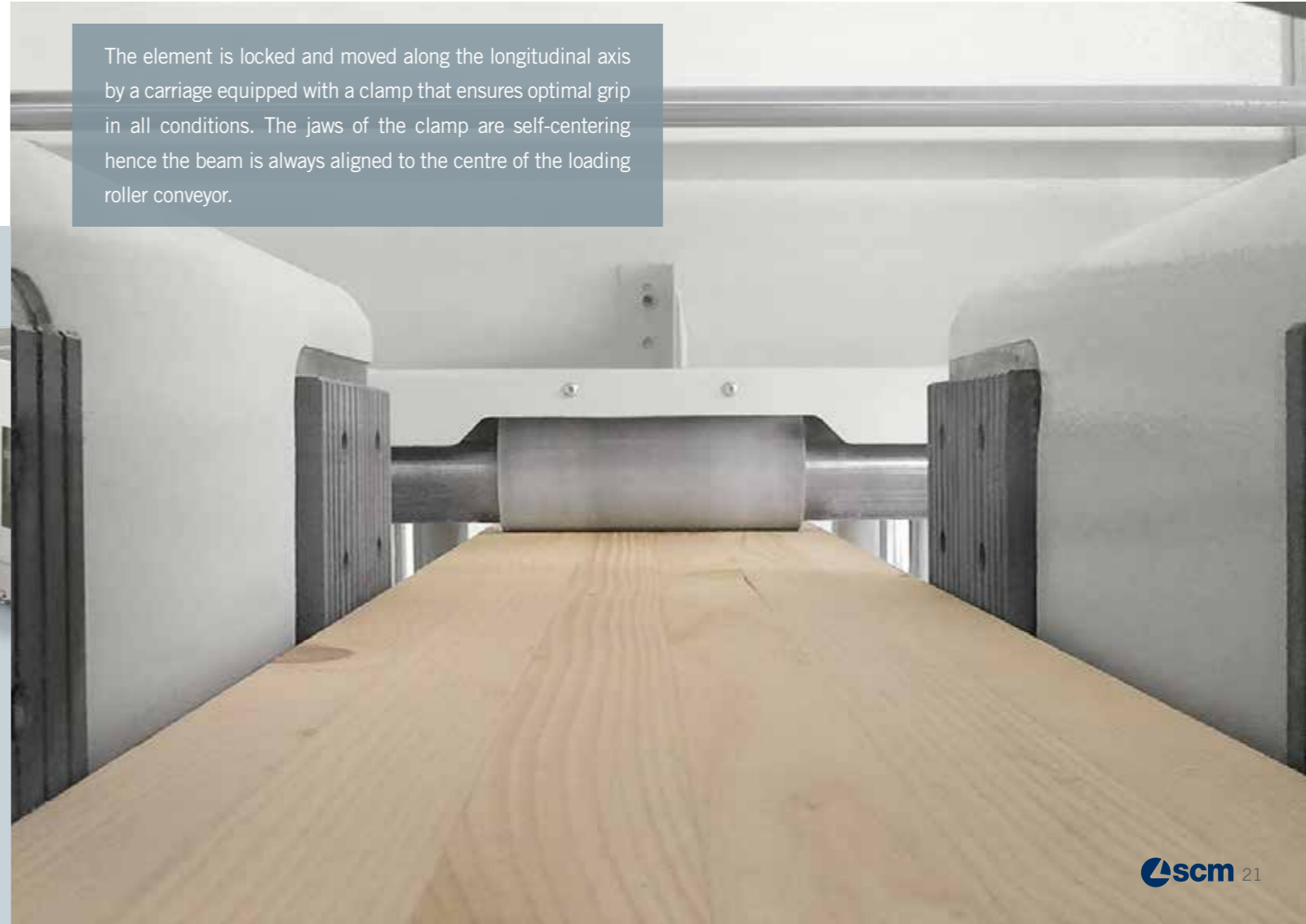

# UNLOADING SYSTEM



With standard positioning on the machine right side, the system manages processed elements unloading.

It is foreseen a clamp with self-centering jaws which, keeping the element firmly in place, moves it in the longitudinal direction.

The high accuracy is guaranteed once again by the presence of horizontal and vertical pressers.

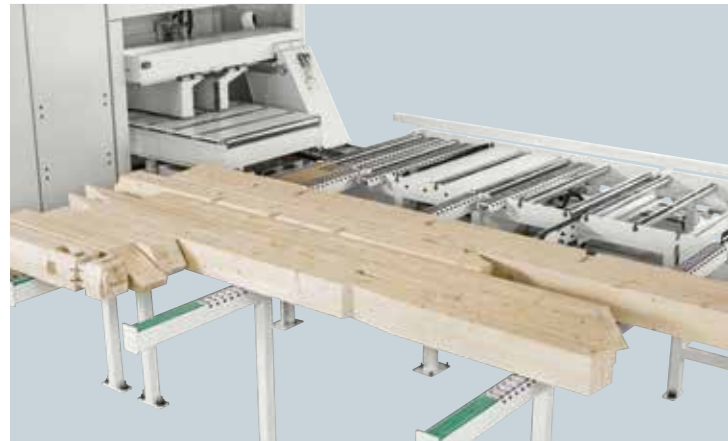

A pusher placed on the rear side of the unloading system moves the element onto an accumulation buffer.

The buffer is made up of a series of fixed supports with variable centre distance, enabling the operator to take the work pieces easily and quickly.



# OPTIONS FOR LOADING AND UNLOADING SYSTEM



Numerous solutions aimed at eliminating the risk of damaging the exposed sides of the element, even in the case of particularly delicate surfaces.

Chromed rollers and metal roller supports for the unloading system guarantee a right sliding of the beam during the handling phases.

It is also possible to handle **round beams** and **“uso fiume” beams**, thanks to specific devices to be fitted to the standard loading system.



The additional supports are ideal for managing packages of glulam beams to be subsequently positioned on the loading system.



They can be extracted manually if necessary, increasing the buffer length by 1 meter.

# CLEANING SYSTEMS



**Intelligent management of waste.** Oikos X offers the possibility of activating the new “waste reduction” function, which allows to cut large parts in slices of 100 mm width, in order to be removed and then reduced in chips more easily.



**Always clean work area.** An inclined rear conveyor belt connected directly to a container collects shavings and waste.



Machining waste are removed by means of a wide conveyor belt placed under the work area.

**The belt moves in two directions:** waste materials are transported to the machine rear side and the short pieces to the cabin front side. The change in the rotation direction is intelligently and automatically managed by cnc.



**Dust containment.** The motorized casings surrounding the beam infeed and outfeed of the work area determine dust and shavings containment inside the cabin.



The operator can easily recover the short pieces through a special door positioned on the front of the cabin.



**Elimination of dust.** Suction outlets are placed on the perimeter of the cabin, in order to collect the finest dust and keep the work area always clearly visible.

# EYE-M CONSOLE



Machine control is at everyone's reach thanks to touch screen control panel, with an **intuitive and powerful operator interface**.

**Always at your service.** The new **eye-M** console allows connection via internet with the SCM Service. Our engineers can so access remotely at all machine levels to perform diagnostics, solve problems or update the machine logic in real time.

**oikos x**



**Video surveillance system.** The video surveillance system allows the operator to monitor in real time the machine status through a monitor positioned above the eye-M console. Use of 4 high-resolution cameras.

The **integrated LED bar** allows the operator to know at any time the status of the machine, even from distance, at a glance.



**Simple identification of every single element.** Connected to the machine control, the printer produces labels with data related to the processed element, to be applied after the unloading phase. The device is positioned under the eye-M console, so that it can be easily used by the operator.

# MAESTRO BEAM&WALL SOFTWARE



## YOUR SCM SOFTWARE TO EVERY TECHNOLOGY

Maestro beam&wall is the software developed by SCM allowing the interface with the industry's best design CADs present on the market. With a few clicks, it is possible to switch from importing BTL files to running the work piece in the machine. Maestro beam&wall gets all the information from the CAD that designed the structure and automatically creates every single program.

### UNIQUE INTERFACE WITH THREE ENVIRONMENTS

Maestro beam&wall allows the rapid and intuitive passage between:

- Programming environment
- Execution environment
- Tool management environment

Integrated function for **nesting technology**. High performance **simulation software**, to test the programs in advance on your PC.

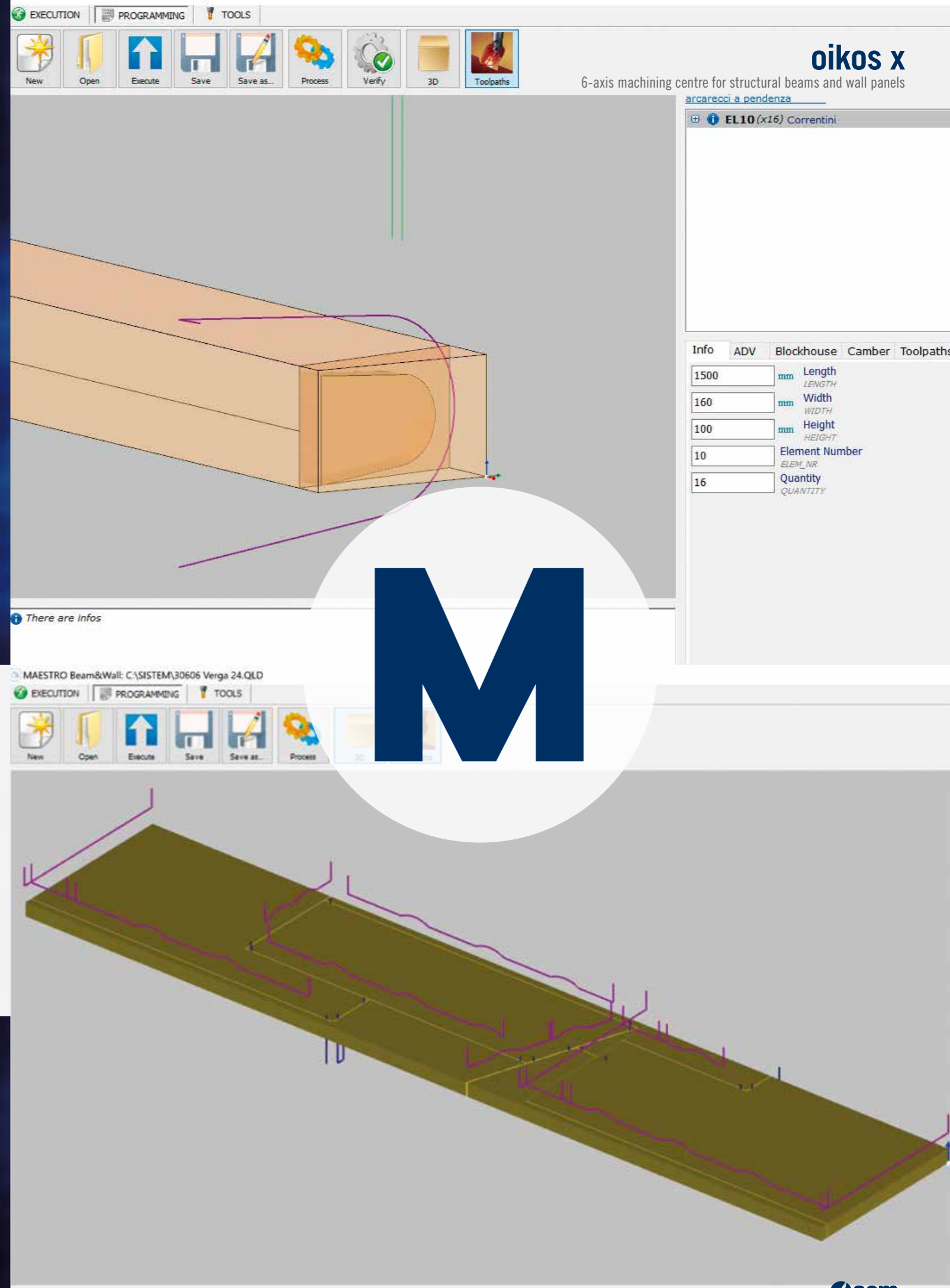

# MAESTRO BEAM&WALL SOFTWARE

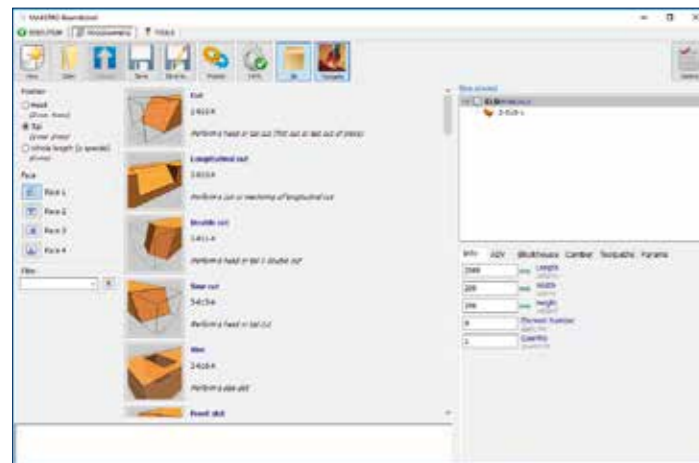

## PROGRAMMING

Dedicated to the development, analysis, check and modification of projects and single operations applied.

The programming environment can also be used to manually create new elements by adding operations from the library of available macros.

During programming, it is possible to optimize the elements to produce, in order to sort the rough work pieces by minimizing the scrap.

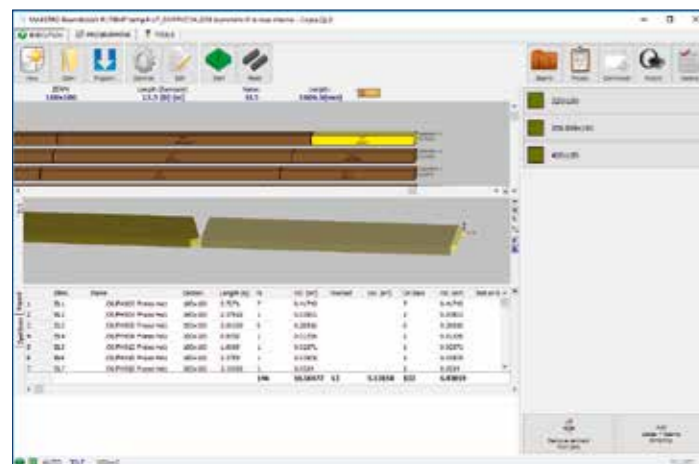

## EXECUTION

Dedicated to the execution of individual projects, it is present both on the programming station and the machine for managing the launch of previously validated programs.

The operator can view the individual elements processed within the available bars, optimize and calculate the minimum length of the required bar.

The execution environment allows the generation of production reports of the projects processed in the machine.

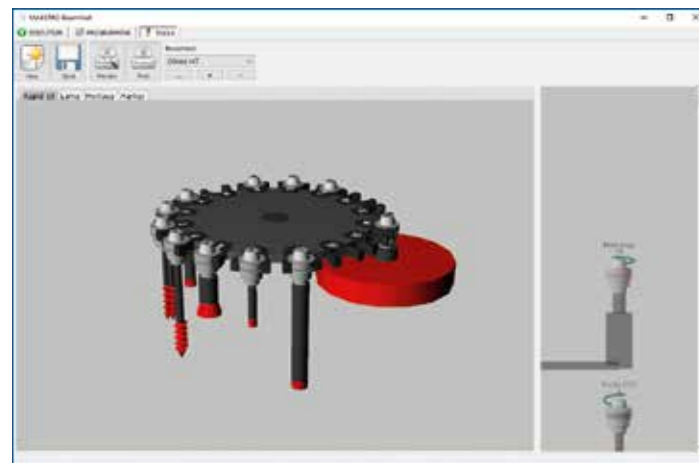

## TOOL MANAGEMENT

Dedicated to the graphic display of the machine equipment and to the management of different tool sets, according to the project to be processed.

Within the environment, it is possible to create new tools in a very rapid way, choosing from a wide range of pre-configured models and simply modifying the relative geometric and technological parameters.

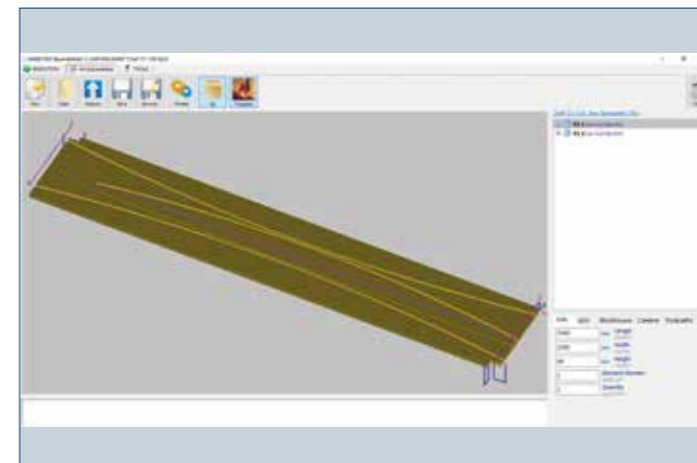

## NESTING TECHNOLOGY

The function is in the Maestro beam&wall software included and allows to process panels of up to 1,250 mm width with nesting technology. Simple import and processing of, even very complex, projects made with modular elements obtained from rough panels, optimizing the cutting of elements within the same "master panel".

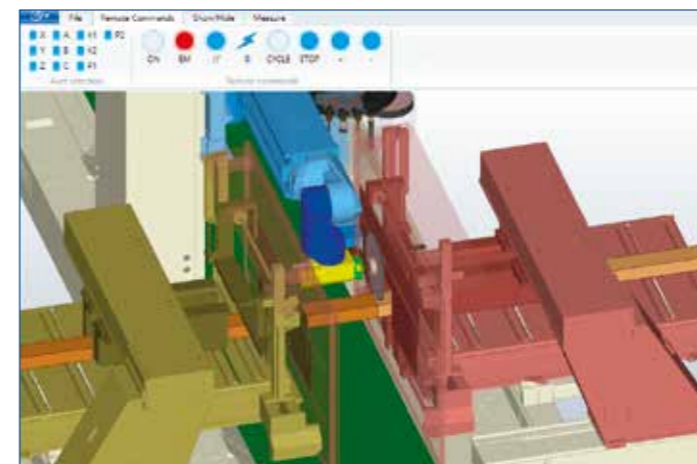

## SIMULATION SOFTWARE

After the optimization phase of the operations, it is possible to launch the project simulation and visualize the operations that will be performed during production, with obvious benefits for the customer:

- Elimination of collision risks
- Elimination of errors
- Elimination of downtime
- Calculation of production time
- Calculation of production costs.

Complete management of the order.





# APPLICATIONS



**oikos x**

6-axis machining centre for structural beams and wall panels

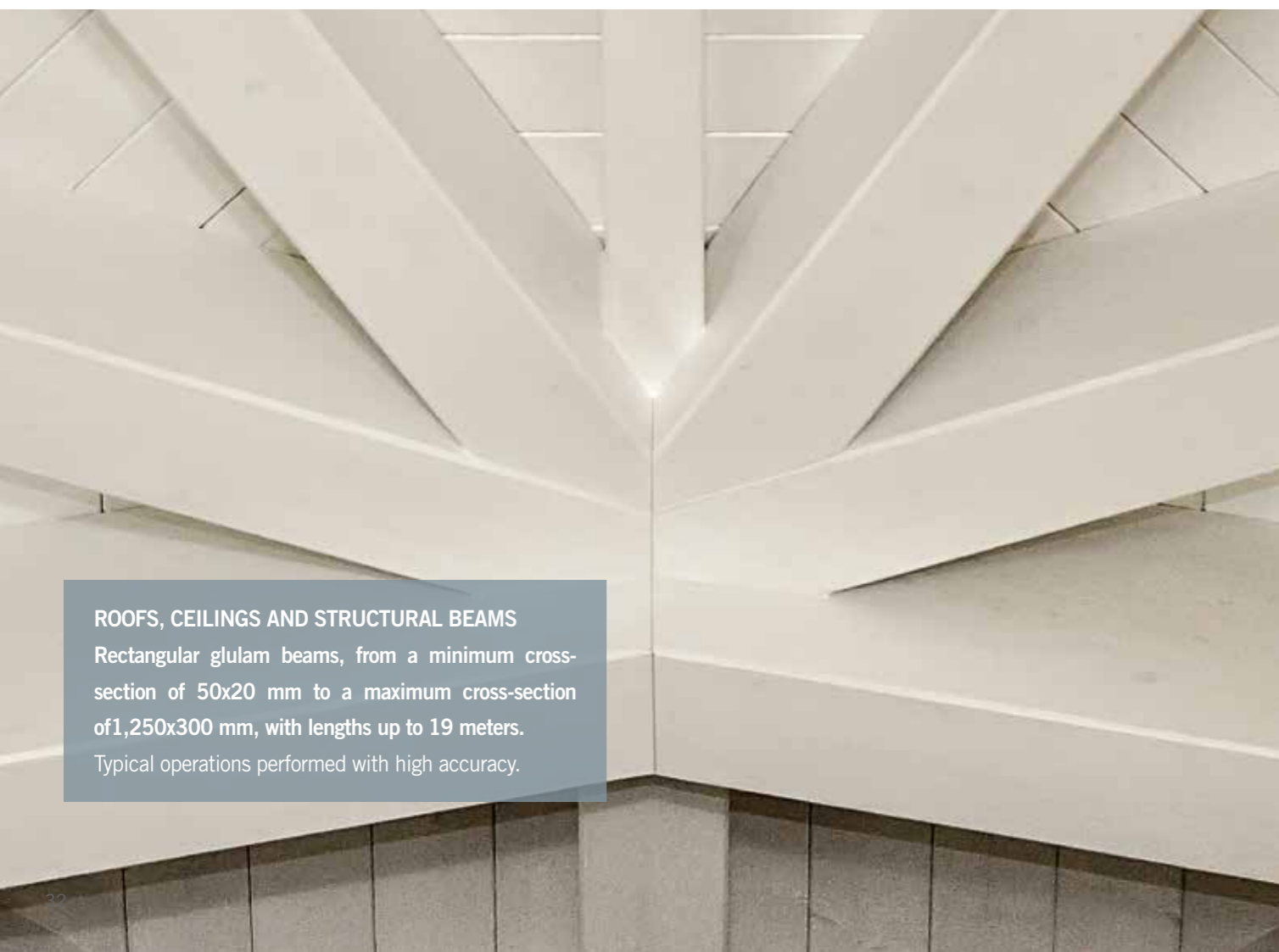

## ROOFS, CEILING AND STRUCTURAL BEAMS

Rectangular glulam beams, from a minimum cross-section of 50x20 mm to a maximum cross-section of 1,250x300 mm, with lengths up to 19 meters. Typical operations performed with high accuracy.



## CLT, X-LAM

X-lam/ CLT panels of up to 1,250 mm width, to use for the construction of modular walls. The nesting technology of Oikos X optimizes the cutting of the elements within the same panel.

# APPLICATIONS

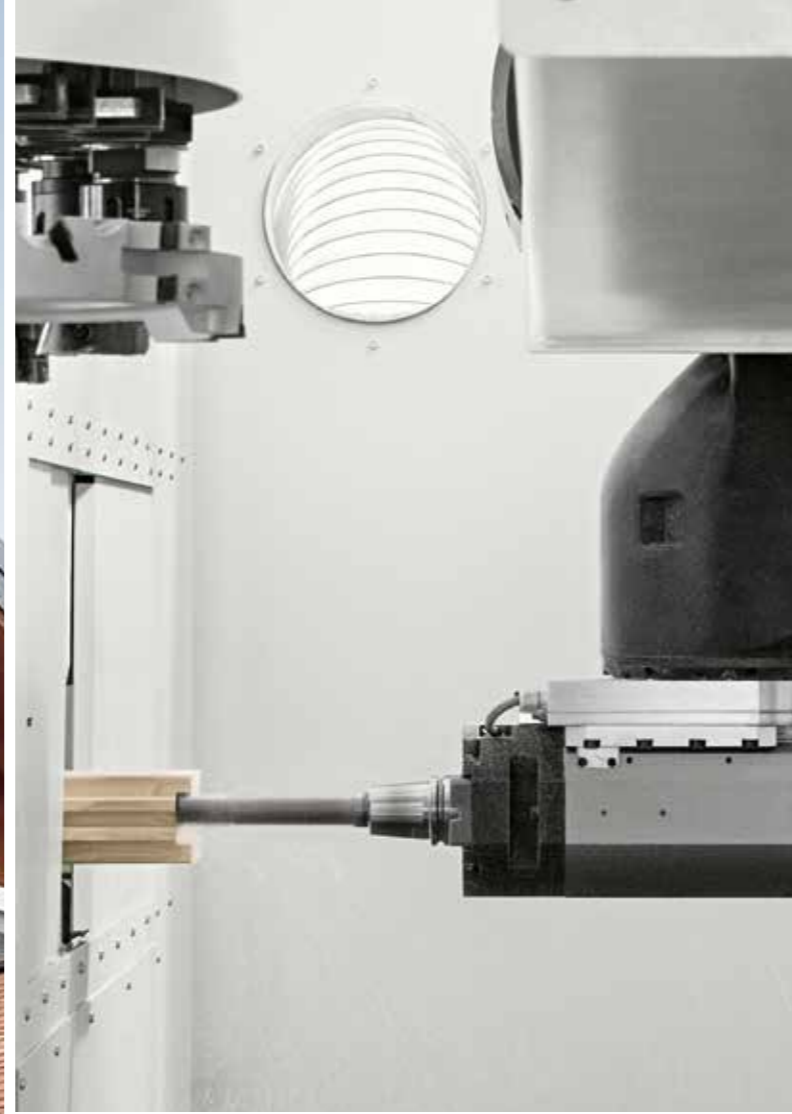

**oikos X**

6-axis machining centre for structural beams and wall panels

## BLOCKHOUSE

Round beams of diameter up to 240 mm and “uso fiume” beams for the construction of Blockhouse structures. Oikos X can be equipped with a kit for beams of particular section.

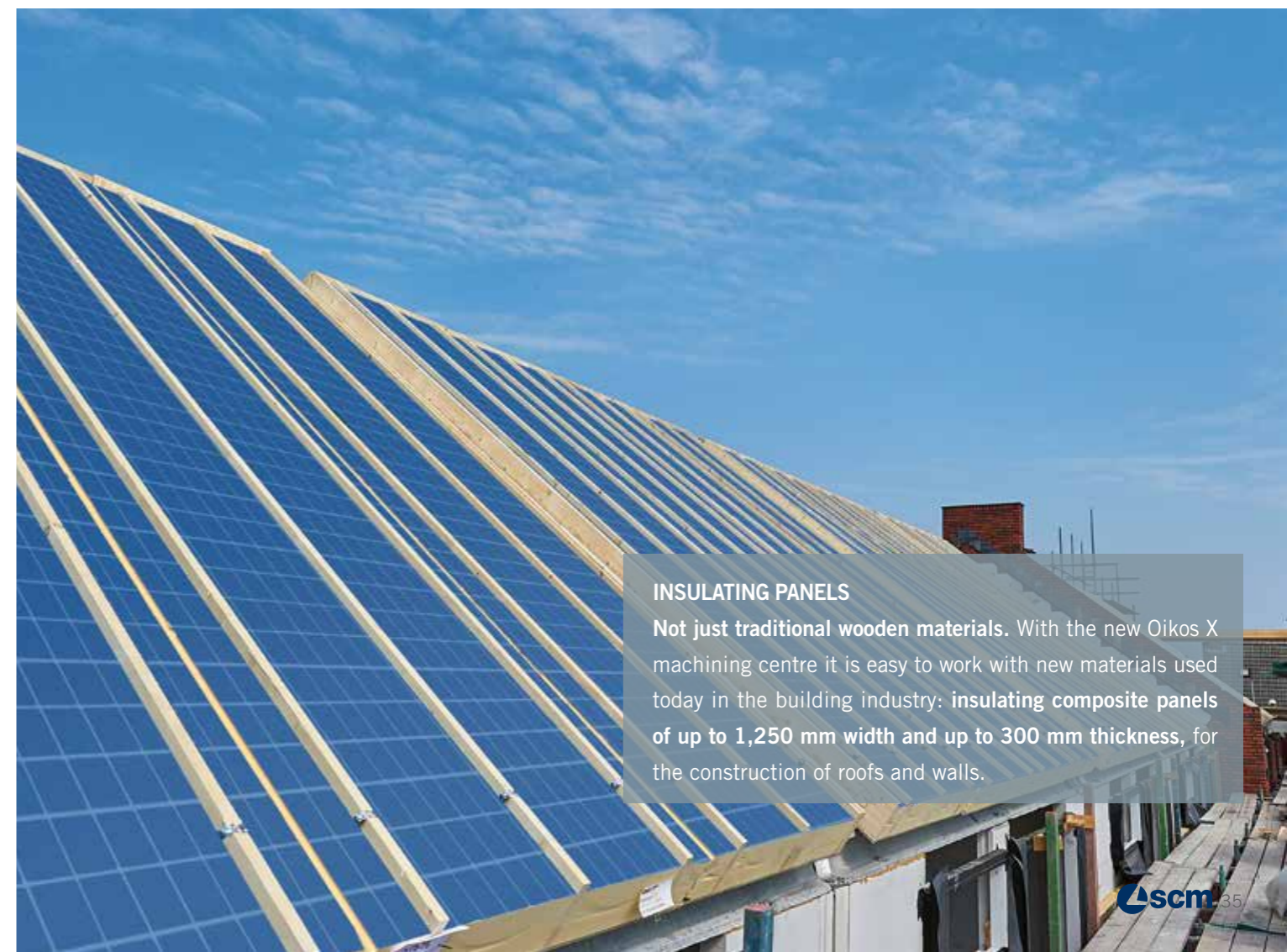

## INSULATING PANELS

Not just traditional wooden materials. With the new Oikos X machining centre it is easy to work with new materials used today in the building industry: **insulating composite panels of up to 1,250 mm width and up to 300 mm thickness**, for the construction of roofs and walls.

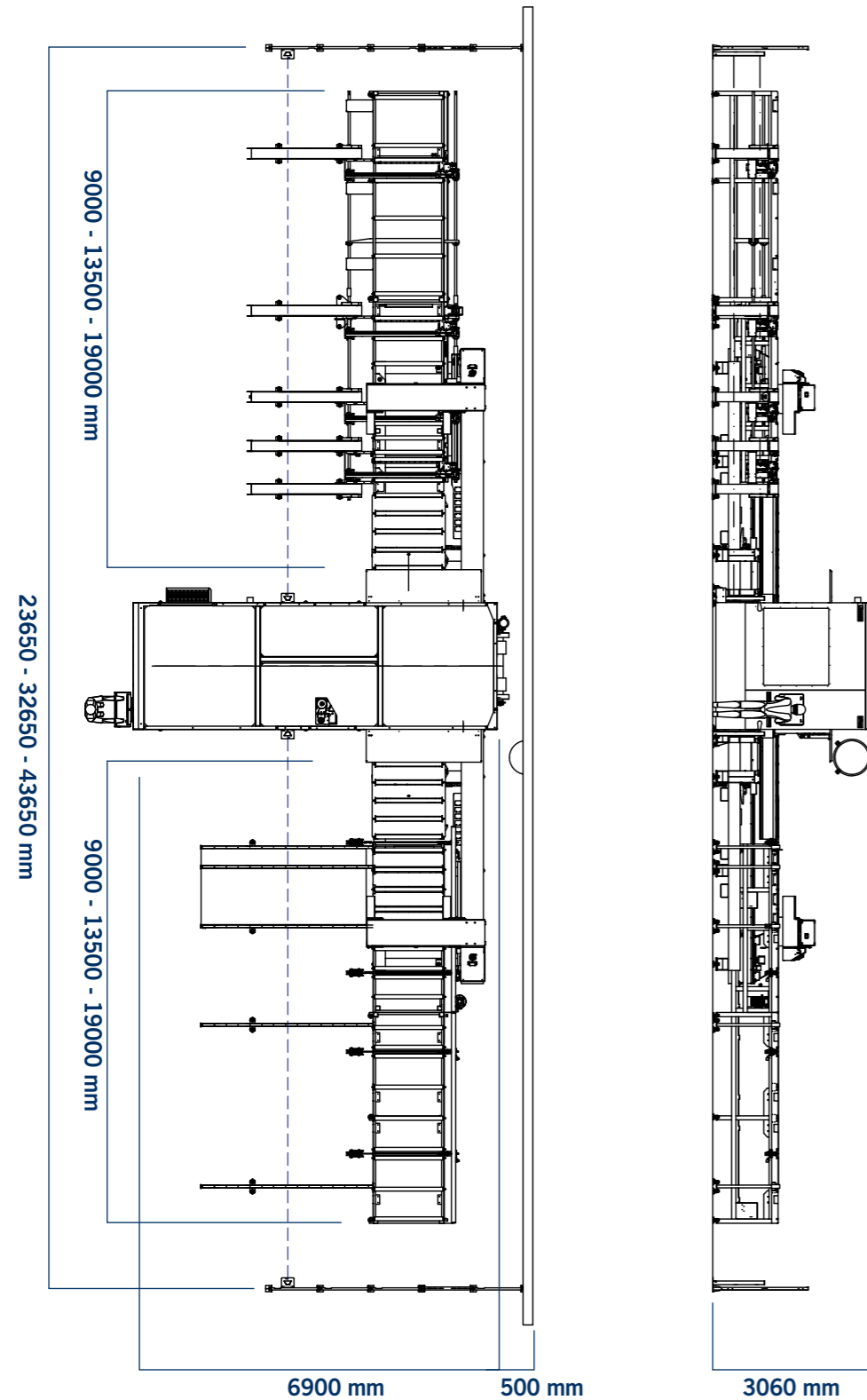

### ELEMENT DIMENSIONS AT INFEEED

Max. Cross-section	mm	1250x300
Min. Cross-section	mm	50x20
Max. Length	mm	9000-13500-19000-24000
Min. Length	mm	1200
Max. Weight	kg	2500-4000

### ELECTROSPINDLE

Max. Power at 6000 rpm (S1)	kW	13-25
Max. Speed rotation	rpm	16000
Max. Torque	Nm	20,7-35

### AXES

X-axis speed	m/min	107
Y-axis speed	m/min	75
Z-axis speed	m/min	28

### TOOL STORES

Rapid 15	n° positions	15
Chainsaw	n° positions	1
Sawblade	n° positions	1
Mortise chain	n° positions	1

### INSTALLATION

Nominal compressed air pressure	bar	6,5
Compressed air consumption	l/min	1300
Suction air consumption	m³/h	8000
Suction outlet D250	n°	2
Suction outlet D120	n°	1
Machine weight	kg	from 19000 to 24000

**COMPANY WITH  
QUALITY SYSTEM  
CERTIFIED BY DNV GL  
= ISO 9001 =**

*The technical data can vary according to the requested machine composition. In this catalogue, machines are shown with options. The company reserves the right to modify technical specifications without prior notice; the modifications do not influence the safety foreseen by the CE Norms.*

Maximum recorded noise levels based on functioning parameters established by EN 848-3:2012.  
Acoustic pressure while working 78,4 dB(A) (measured according to EN ISO 11202:2010, K variance = 4dB)  
Acoustic power while working 100,6 dB(A) (measured according to EN ISO 3746:2010, K variance = 4 dB).  
Despite the existence of a correlation between "conventional" noise emission values mentioned above and average personal exposure of the operators during the 8 hours, these also depend on the specific functioning conditions, length of exposure, acoustics characteristics of the working environment and by the presence of additional sources of noise, that is the number of machines and adjacent processes.

# PROMPT AND EXPERT TECHNICAL SUPPORT THROUGH A NETWORK OF 1000 TECHNICIANS AND AN INVENTORY OF 36,000 SPARE PARTS.

HIGHLY SPECIALISED TECHNICIANS, EFFICIENT MANAGEMENT AND 6 SPARE PARTS BRANCHES AROUND THE WORLD GUARANTEE A CLOSE, SAFE AND EFFECTIVE TECHNICAL SUPPORT.

## SERVICE

SCM provides a service that goes beyond the purchase, to guarantee the long term performance of your technological production system and peace of mind for your business.

### A COMPLETE RANGE OF AFTER-SALES SERVICES

- installation and start-up of machines, cells, lines and systems
- tailored training programs
- telephone support to reduce times and costs when machines are not working
- preventive maintenance programs to guarantee long term performance
- complete renovation of machines and plants to renew the added value of the investments
- custom upgrading to update machines and plants and meet new production requirements

## SPARE PARTS

SCM Group can count on 140 spare parts professionals worldwide to meet any request with real time shipments.



### 36,000 SPARE PARTS

Our spare parts inventory, with a value of 12 million euros, covers every single machine



### SPARE PARTS GUARANTEED

We guarantee also hard to find parts, with 3,5 million euros invested in "critical" spare parts.



### IMMEDIATE AVAILABILITY

Over 90% of orders received are carried out the same day thanks to the huge inventory available.



### 6 BRANCHES AROUND THE WORLD

The spare parts service can count on worldwide support (Rimini, Singapore, Shenzhen, Moscow, Atlanta, São Bento do Sul)



### 500 SHIPMENTS A DAY

# THE STRONGEST WOOD TECHNOLOGIES ARE IN OUR DNA

## SCM. A HERITAGE OF SKILLS IN A UNIQUE BRAND

Over 65 years of success gives SCM the centre stage in woodworking technology. This heritage results from bringing together the best know-how in machining and systems for wood-based manufacturing. SCM is present all over the world, brought to you by the widest distribution network in the industry.

65 years history

3 main production sites in Italy

300.000 square metres of production space

17.000 machines manufactured per year

90% export

20 foreign branches

350 agents and dealers

500 support technicians

500 registered patents

In SCM's DNA also strength and solidity of a great Group. The SCM Group is a world leader, manufacturing industrial equipment and components for machining the widest range of materials.

## SCM GROUP, A HIGHLY SKILLED TEAM EXPERT IN INDUSTRIAL MACHINES AND COMPONENTS

### INDUSTRIAL MACHINERY

Stand-alone machines, integrated systems and services dedicated to processing a wide range of materials.



WOODWORKING TECHNOLOGIES



TECHNOLOGIES FOR PROCESSING COMPOSITE MATERIALS, ALUMINIUM, PLASTIC, GLASS, STONE, METAL

### INDUSTRIAL COMPONENTS

Technological components for the Group's machines and systems, for those of third-parties and the machinery industry.



SPINDLES AND TECHNOLOGICAL COMPONENTS



ELECTRIC PANELS



METALWORK



CAST IRON

